

INNOVATION ISN'T JUST WRAPPING FIBERGLASS AROUND OLD WELL TANK TECHNOLOGY.

[INTRODUCING THE NEW FLEX-LITE WITH CAD-2]



Precision injection molded domes for uniform wall thickness and consistent engineered dome profiles.

High tech spin welding process permanently fuses precision injection molded domes to the extruded cylinder.

Flexcon's patented CAD-2 controlled action diaphragm design enables the tank's water chamber to be sized for the optimum drawdown capacity of each tank.

Rugged base engineered to withstand maximum loads and extreme environmental conditions.

Reinforced with durable, continuous strand fiberglass and sealed from the environment with weather resistant epoxy resin. Suitable for underground installation.

SUPER SIZED
Our larger tank sizes offer greater drawdown capacity.

CAD-2
New CAD-2 diaphragm technology: strong 100% butyl diaphragm and copolymer polypropylene lower water chamber for maximum water and air separation.

Tough, injection molded, rigid PVC connection for easy installation and life-time performance.

Unlike other composite tanks that hide tired old bag technology in a plastic shell, the Flex-Lite FL composite tank uses the latest evolution of the field proven controlled action diaphragm design that Flexcon introduced in Well-Rite steel tanks in 1988.

The Flex-Lite FL series' improved CAD-2 diaphragm design is stronger and won't crease and wear out like bag designs. It features a chlorine resistant 100% butyl diaphragm with a precision molded copolymer polypropylene lower water chamber for superior air and water separation.

This patented design allows each size tank to have a properly sized water chamber, matched to the drawdown performance of that tank. When it comes to performance and durability, the CAD-2 system cannot be beat.

So if you are looking for the proven performance of a Flexcon steel tank in a lightweight composite design, Flex-Lite FL is the answer.



Patent Pending



FL/CAD-2

MATERIALS OF CONSTRUCTION

- **Top and bottom domes:** Injection molded copolymer polypropylene
- **Shell:** Extruded copolymer polypropylene
- **Outer shell:** Fiberglass-wound, coated with epoxy resin
- **Water chambers:** Top diaphragm is 100% butyl rubber, lower water chamber is copolymer polypropylene
- **Base:** Copolymer polypropylene
- **Connection:** Rigid Schedule 80 PVC
- **Air valve:** Brass valve with o-ring seal
- **Warranty:** 5 year limited

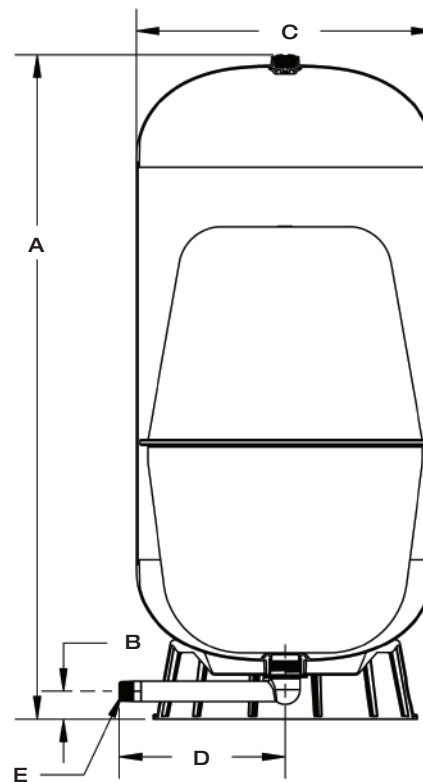

COMPOSITE TANK DIMENSIONS

Model	Total Tank Volume		A Height		B Floor to CL		C Diameter		D CL to fitting end		E Connection	Total Weight	
	gal	liters	in	cm	in	cm	in	cm	in	cm		lbs	kilos
FL 5	15	56.8	25.6	64.0	1.75	4.4	16.5	41.9	9.4	23.9	1" NPT	19.0	8.6
FL 7	22	83.3	34.1	84.1	1.75	4.4	16.5	41.9	9.4	23.9	1" NPT	24.0	10.9
FL 12	35	132.5	48.9	121.7	1.75	4.4	16.5	41.9	9.4	23.9	1" NPT	33.5	15.2
FL 13SQ	38	143.8	29.75	74.7	2.25	5.7	24.2	61.5	11.9	30.2	1 1/4" sch 80	38.0	15.9
FL 17	50	189.3	43.3	109.0	2.25	5.7	21.4	54.4	11.9	30.2	1 1/4" NPT	47.0	21.3
FL 22	65	246.0	51.3	129.3	2.25	5.7	21.4	54.4	11.9	30.2	1 1/4" NPT	58.0	26.3
FL 28	82	310.4	64.7	163.3	2.25	5.7	21.4	54.4	11.9	30.2	1 1/4" NPT	69.5	31.5
FL 30	90	340.7	57.0	143.8	2.25	5.7	24.2	61.5	13.4	34.0	1 1/4" NPT	77.0	34.9
FL 40	119	450.4	72.1	182.1	2.25	5.7	24.2	61.5	13.4	34.0	1 1/4" NPT	99.5	45.1

Maximum working pressure 125 psig. Maximum working temperature, internal & external 120° F. Tank pre-charge 38 psig.

QUICK SIZING CHART

Model	Total Tank Volume		Total Drawdown*					
	gal	liters	20/40		30/50		40/60	
	gal	liters	gal	liters	gal	liters	gal	liters
FL 5	15	56.8	6.00	24.1	5.1	20.4	4.4	17.7
FL 7	22	83.3	8.80	32.2	7.5	27.2	6.5	23.6
FL 12	35	132.5	14.10	52.3	11.9	44.2	10.3	38.3
FL 13SQ	38	143.8	13.89	51.8	11.8	44.0	10.5	39.4
FL 17	50	189.3	20.10	76.4	17.0	64.6	14.7	56.0
FL 22	65	246.0	26.10	100.5	22.1	85.0	19.1	73.6
FL 28	82	310.4	33.00	120.7	27.9	102.0	24.1	88.4
FL 30	90	340.7	36.20	136.7	30.6	115.6	26.5	100.1
FL 40	119	450.4	47.90	181.0	40.5	153.0	35.0	132.5

*Total drawdown assumes tank pre-charge set at 2 psi below cut-in pressure. Drawdown can be affected by many factors, including temperature, pressure, and elevation.

> www.flexconind.com
 > 781-986-2424
 > 300 Pond Street
 > Randolph, MA 02368

