



Finally, a well tank specifically designed for contractors!

You want to install the best possible tank for your clients, but lets face it, you won't get the job if you can't do it at a competitive price. Engineered with installers' needs in mind, FLEX 2 PRO well tanks deliver the same CAD-2 technology we offer in our high-end-tanks, at a price point that contractors love.

So, if you want to give your clients unmatched performance for a down-to-earth price, FLEX 2 PRO is the best bang for your buck!



16 - gauge solid steel tank, finished with highest quality urethane paint to stand up to the dampest basement or crawl space.

CAD-2 CAD-2 diaphragm technology: strong, 100% butyl diaphragm and copolymer polypropylene lower water chamber for maximum water and air separation.

Steel clench ring regulates movement and prevents diaphragm from rubbing against tank wall.

Condensation-reducing design virtually eliminates external corrosion.



Patented, welded, stainless steel water connection has separate air and water seals.





WWT SERIES

Well Tank

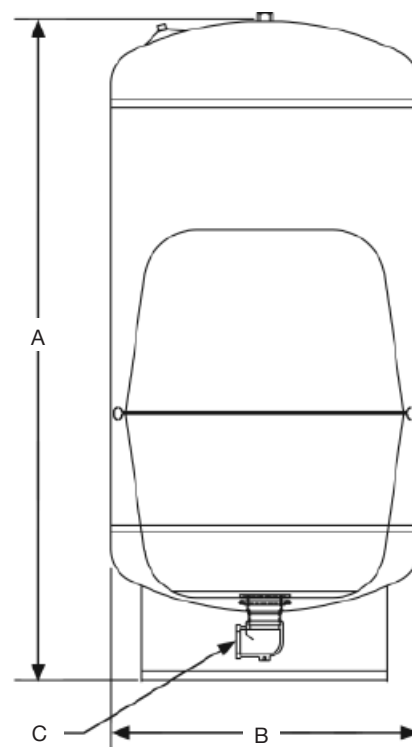

MATERIALS OF CONSTRUCTION

- **Tank:** 16-gauge cold rolled steel
- **Finish:** Appliance-quality paint for indoor or outdoor installation
- **Water chambers:** Top diaphragm is 100% butyl rubber, lower water chamber is copolymer polypropylene
- **Connection:** Welded stainless steel NPT thread
- **Air valve:** Brass valve with O-ring seal
- **Testing:** High pressure, seam weld, helium, final precharge check
- **Warranty:** 5 year

DIMENSIONS & CAPACITIES

Model	Total Tank Volume		A Height		B Diameter		C Connection	Total Weight	
	gal	liters	in	cm	in	cm		lbs	kilos
WWT 14	14	60	22	55.88	16	40.64	1" NPT	28.0	12.7
WWT 20	20	80	29	73.66	16	40.64	1" NPT	36.0	16.3
WWT 25	26	100	34.5	87.63	16	40.64	1" NPT	41.0	18.6
WWT 30	32	120	27.75	70.48	21	53.34	1 1/4" NPT	54.0	24.5
WWT 35	33.4	130	42.75	108.58	16	40.64	1 NPT	49.0	22.2
WWT 45	44	170	36.25	92.07	21	53.34	1 1/4" NPT	67.0	30.4
WWT 65	62	240	48	121.92	21	53.34	1 1/4" NPT	82.0	37.2
WWT 80	81	310	62	157.48	21	53.34	1 1/4" NPT	99.0	44.9
WWT 85	85	325	44.5	113.03	26	66.04	1 1/4" NPT	121.0	54.9
WWT 120	119	450	59.75	151.76	26	66.04	1 1/4" NPT	153.0	69.5

Maximum working pressure 125 psig. Maximum working temperature, internal & external 140° F. Tank pre-charge 38 psig.

QUICK SIZING CHART

Model	Total Tank Volume		Total Drawdown*					
	gal	liters	20/40		30/50		40/60	
	gal	liters	gal	liters	gal	liters	gal	liters
WWT 14	14	60	5.6	21.4	4.8	18.1	4.1	15.6
WWT 20	20	80	8.1	30.5	6.8	25.8	5.9	22.3
WWT 25	26	100	10.5	39.7	8.9	33.6	7.7	29.0
WWT 30	32	120	12.9	48.8	10.9	41.3	9.4	35.7
WWT 35	33.4	130	13.3	50.3	11.3	42.6	9.7	36.8
WWT 45	44	170	17.7	67.1	15.0	56.8	13.0	49.1
WWT 65	62	240	25.0	94.6	21.1	80.0	18.3	69.2
WWT 80	81	310	32.6	123.6	27.6	104.5	23.9	90.4
WWT 85	85	325	34.3	129.7	29.0	109.7	25.1	94.9
WWT 120	119	450	48.0	181.5	40.6	153.6	35.1	132.9

*Total drawdown assumes tank pre-charge set at 2 psi below cut-in pressure. Drawdown can be affected by many factors, including temperature, pressure, and elevation.

