



Light in weight, heavy duty in performance!

Don't be fooled by Flex-Lite's light weight and good looks. Beneath it's super strong, weather impervious composite shell is Flexcon's patented, CAD-2 diaphragm that's second to none!

If you're looking for the unmatched performance of a Flexcon steel tank in a lightweight, rustproof shell, Flex-Lite is just the ticket.



Injection molded domes for precise, uniform wall thickness and consistently engineered dome profiles.

High tech spin welding process permanently fuses injection molded domes to the extruded cylinder.

Reinforced with durable, continuous strand fiberglass and sealed from the environment with weather resistant epoxy resin. Suitable for underground installation.

SUPER SIZED
OUR LARGER TANK SIZES OFFER GREATER DRAWDOWN CAPACITY.

CAD-2

CAD-2 diaphragm technology: strong, 100% butyl diaphragm and copolymer polypropylene lower water chamber for maximum water and air separation.

Rugged base engineered to withstand maximum loads and extreme environmental conditions.

Tough, injection molded, rigid PVC connection for easy installation and lifetime performance.





FL/CAD-2 Composite

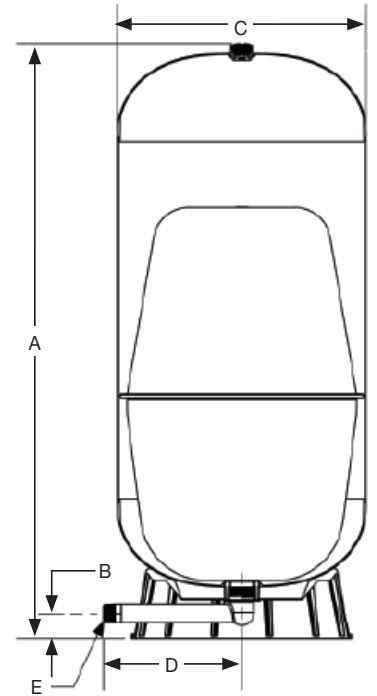

MATERIALS OF CONSTRUCTION

- **Top and bottom domes:** Injection molded copolymer polypropylene
- **Shell:** Extruded copolymer polypropylene
- **Outer shell:** Fiberglass-wound, coated with epoxy resin
- **Water chambers:** Top diaphragm is 100% butyl rubber, lower water chamber is copolymer polypropylene
- **Base:** Copolymer polypropylene
- **Connection:** Rigid schedule 80 PVC
- **Air valve:** Easy to access brass valve with o-ring seal
- **Testing:** High pressure, seam weld, helium, final precharge check
- **Warranty:** 5 year limited



COMPOSITE TANK DIMENSIONS

Model	Total Tank Volume		A Height		B Floor to CL		C Diameter		D CL to fitting end		E Connection	Total Weight	
	gal	liters	in	cm	in	cm	in	cm	in	cm		lbs	kilos
FL 5	15	56.8	25.60	65.0	1.75	4.4	16.5	41.9	9.4	23.9	1" NPT	19.0	8.6
FL 7	22	83.3	34.10	87.0	1.75	4.4	16.5	41.9	9.4	23.9	1" NPT	24.0	10.9
FL 12	35	132.5	48.90	124.2	1.75	4.4	16.5	41.9	9.4	23.9	1" NPT	33.5	15.2
FL 13SQ	38	143.8	30.50	76.0	2.25	5.7	24.2	61.5	11.9	30.2	1 1/4" sch 80	35.0	15.9
FL 14	40	151.0	39.20	99.6	2.25	5.7	21.4	54.4	11.9	30.2	1 1/4" NPT	38.0	17.2
FL 17	50	189.3	43.30	110.0	2.25	5.7	21.4	54.4	11.9	30.2	1 1/4" NPT	47.0	21.3
FL 22	65	246.0	53.50	130.3	2.25	5.7	21.4	54.4	11.9	30.2	1 1/4" NPT	58.0	26.3
FL 28	82	310.4	64.70	164.3	2.25	5.7	21.4	54.4	11.9	30.2	1 1/4" NPT	69.5	31.5
FL 30	90	340.7	57.00	145.0	2.25	5.7	24.2	61.5	13.4	34.0	1 1/4" NPT	77.0	34.9
FL 40	119	450.4	72.10	183.1	2.25	5.7	24.2	61.5	13.4	34.0	1 1/4" NPT	99.5	45.1

Maximum working pressure 125 psig. Maximum working temperature, internal & external 120° F. Tank pre-charge 38 psig.

QUICK SIZING CHART

Model	Total Tank Volume		Total Drawdown*					
	gal	liters	20/40		30/50		40/60	
	gal	liters	gal	liters	gal	liters	gal	liters
FL 5	15	56.8	6.00	24.1	5.1	20.4	4.4	17.7
FL 7	22	83.3	8.80	32.2	7.5	27.2	6.5	23.6
FL 12	35	132.5	14.10	52.3	11.9	44.2	10.3	38.3
FL 13SQ	38	143.8	13.90	51.8	11.8	44.0	10.5	39.4
FL 14	40	151.0	16.10	60.9	13.6	51.4	11.8	44.6
FL 17	50	189.3	20.10	76.4	17.0	64.6	14.7	56.0
FL 22	65	246.0	26.10	100.5	22.1	85.0	19.1	73.6
FL 28	82	310.4	33.00	120.7	27.9	102.0	24.1	88.4
FL 30	90	340.7	36.20	136.7	30.6	115.6	26.5	100.1
FL 40	119	450.4	47.90	181.0	40.5	153.0	35.0	132.5

*Total drawdown assumes tank pre-charge set at 2 psi below cut-in pressure. Drawdown can be affected by many factors, including temperature, pressure, and elevation.

