



# The secret to improving your well tank business, is having the right connections!

## H2 PRO SS, WITH STAINLESS STEEL WATER CONNECTION.

Engineered with the contractor in mind, the improved Flexcon H2Pro SS comes standard with a stainless steel water connection. And, it's the only well water tank in this category that offers CAD-2 technology.

The result is superior air and water separation with unmatched performance.

H2Pro SS, it pays to have good connections!



16 gauge solid steel tank, finished with the highest quality blue or grey urethane paint.

Water chamber is independent of tank walls, allowing diaphragm to be sized properly for each tank.

**CONTROLLED ACTION DIAPHRAGM**  
MAXIMIZES DRAWDOWN & ELIMINATES CHAFING

# CAD-2

CAD-2 diaphragm technology: strong, 100% butyl diaphragm and copolymer polypropylene lower water chamber for maximum water and air separation.

Condensation reducing design virtually eliminates external corrosion.



Patented, welded, all stainless steel water connection has separate air and water seals.



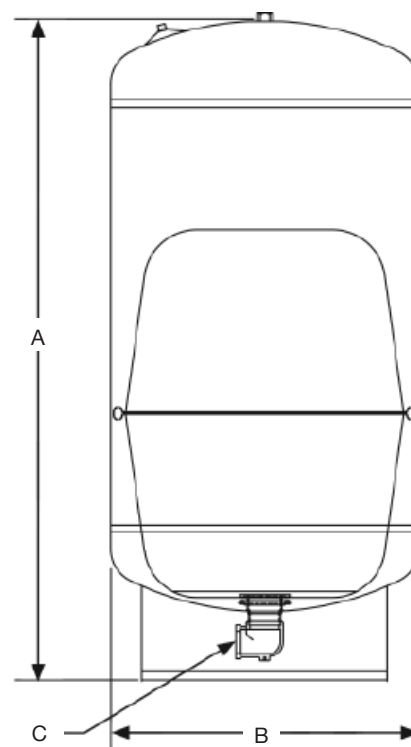

## MATERIALS OF CONSTRUCTION

- **Tank:** 16 gauge cold rolled steel
- **Finish:** Appliance quality paint for indoor or outdoor installation
- **Water chambers:** Top diaphragm is 100% butyl rubber, lower water chamber is copolymer polypropylene
- **Connection:** Stainless steel
- **Air valve:** Brass valve with o-ring seal
- **Testing:** High pressure, seam weld, helium, final precharge check
- **Warranty:** 5 year limited



## DIMENSIONS & CAPACITIES

Model	Total Tank Volume		A Height		B Diameter		C Connection	Total Weight	
	gal	liters	in	cm	in	cm		lbs	kilos
(G)H2P 14	14	60	22	55.88	16	40.64	1" NPT	28.0	12.7
(G)H2P 20	20	80	29	73.66	16	40.64	1" NPT	36.0	16.3
(G)H2P 25	26	100	34.5	87.63	16	40.64	1" NPT	41.0	18.6
(G)H2P 30	32	120	27.75	70.48	21	53.34	1 1/4" NPT	54.0	24.5
(G)H2P 35	33.4	130	42.75	108.58	16	40.64	1 NPT	49.0	22.2
(G)H2P 45	44	170	36.25	92.07	21	53.34	1 1/4" NPT	67.0	30.4
(G)H2P 65	62	240	48	121.92	21	53.34	1 1/4" NPT	82.0	37.2
(G)H2P 80	81	310	62	157.48	21	53.34	1 1/4" NPT	99.0	44.9
(G)H2P 85	85	325	44.5	113.03	26	66.04	1 1/4" NPT	121.0	54.9
(G)H2P 120	119	450	59.75	150.49	26	66.04	1 1/4" NPT	153.0	69.5

Maximum working pressure 125 psig. Maximum working temperature, internal & external 140° F. Tank pre-charge 38 psig.

## QUICK SIZING CHART

Model	Total Tank Volume		Total Drawdown*					
	gal	liters	20/40		30/50		40/60	
	gal	liters	gal	liters	gal	liters	gal	liters
(G)H2P 14	14	60	5.6	21.4	4.8	18.1	4.1	15.6
(G)H2P 20	20	80	8.1	30.5	6.8	25.8	5.9	22.3
(G)H2P 25	26	100	10.5	39.7	8.9	33.6	7.7	29.0
(G)H2P 30	32	120	12.9	48.8	10.9	41.3	9.4	35.7
(G)H2P 35	33.4	130	13.3	50.3	11.3	42.6	9.7	36.8
(G)H2P 45	44	170	17.7	67.1	15.0	56.8	13.0	49.1
(G)H2P 65	62	240	25.0	94.6	21.1	80.0	18.3	69.2
(G)H2P 80	81	310	32.6	123.6	27.6	104.5	23.9	90.4
(G)H2P 85	85	325	34.3	129.7	29.0	109.7	25.1	94.9
(G)H2P 120	119	450	48.0	181.5	40.6	153.6	35.1	132.9

\*Total drawdown assumes tank pre-charge set at 2 psi below cut-in pressure. Drawdown can be affected by many factors, including temperature, pressure, and elevation.

- (G) = GRAY

